



"FALCOLEK", SERIES 23.5	
Art.no.	Description
23.500.000	base section, roof with profiled aluzinc sheets
23.500.712	additional charge for profiled aluzinc sheets powder-coated
23.510.000	add-on section, roof with profiled aluzinc sheets
23.510.712	additional charge for profiled aluzinc sheets powder-coated
23.540.000	end wall with profiled aluzinc sheets
23.540.712	additional price for profiled aluzinc sheets powder-coated
23.547.000	end wall with pinewood lattice work
23.548.000	end wall with hardwood lattice work
23.550.300	slanting side wall with profiled aluzinc sheets
23.550.712	additional charge for profiled aluzinc sheets powdercoated

1 "FALCOLEK", SERIES 23.5

A popular shelter, particularly with schools.
 Section length 4000 mm between the centres of the trusses. Roof span 3700 mm. Parking options per 4 metre section: 20 bicycles at a centre to centre distance of 187.5 mm or 10 on their own stand. Trusses made of IPE-100, 50x50 mm and 40x40 mm tubular section. Hot-dip galvanised before embedding in concrete corbels. All fixings are made of stainless steel or special aluminium

A variety of playful options are available on the series 23.5 model in terms of end wall. In addition to the range of materials such as pinewood latticework, aluzinc sheet piling with or without powder-coating and solid plastic sheeting, there are also many shape options available.

N.B. The lowest cost per covered bike space in our range. Also available with a roof span of 4300 mm for optimum protection. Other roof and wall coverings are available on request.

"FalcoLek" without end wall

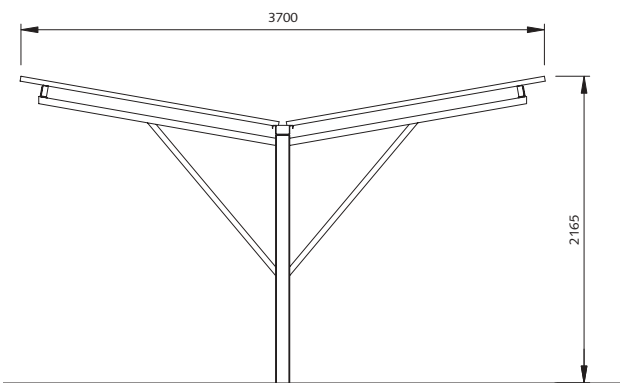

"FalcoLek" with pinewood/hardwood lattice work

